

Automated Driving Society in MIC

ITS Promotion Office, Telecommunications Bureau
Ministry of Internal Affairs and Communications (MIC)
JAPAN

The Expected Role of Automated Driving and Mobility Services

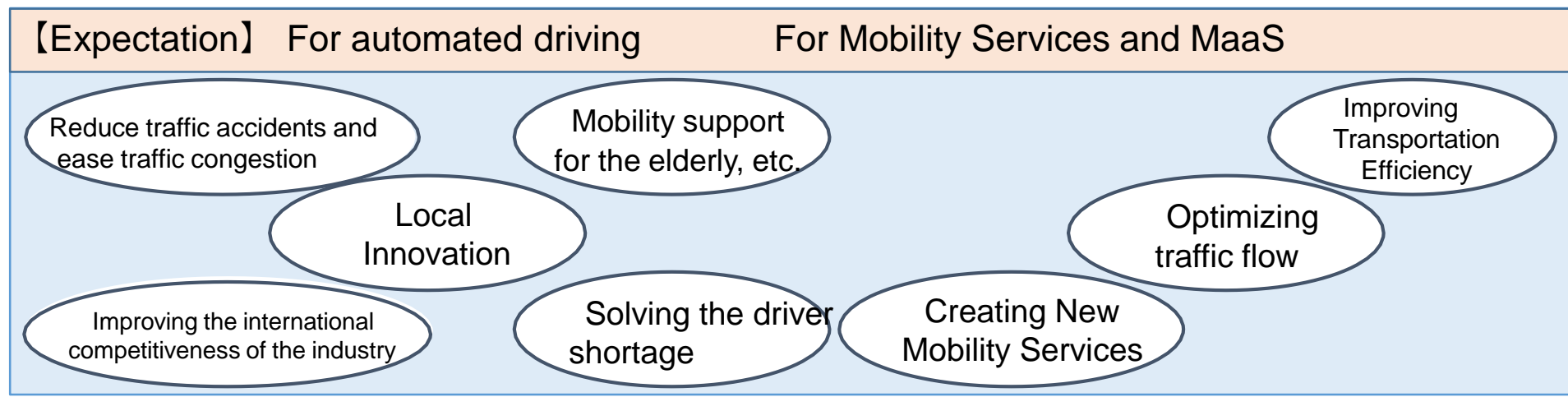

※MaaS : Mobility as a Service

Automated Driving x MaaS

- ❑ Safe, convenient, low-cost and free movement for everyone.
- ❑ Realizing a mobility society in which all traffic flows are optimized.

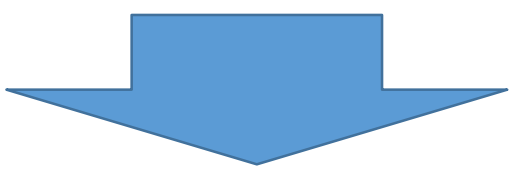

**Creating new methods of transportation and logistics.
“Affluent Life“ by “Mobility Revolution“.**

Increasingly Advanced ITS

Systems that are being used across the country

Services such as congestion information and fare settlement are provided.

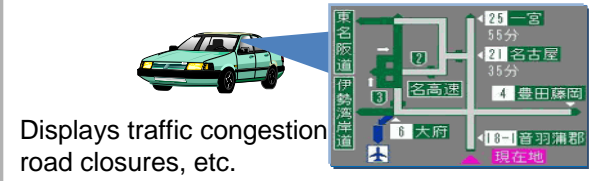

VICS



ETC



ETC2.0

The system has been promoted by automakers in recent years

Autonomous ITS

The system uses on-board sensors such as cameras and radar to provide advanced driving assistance.

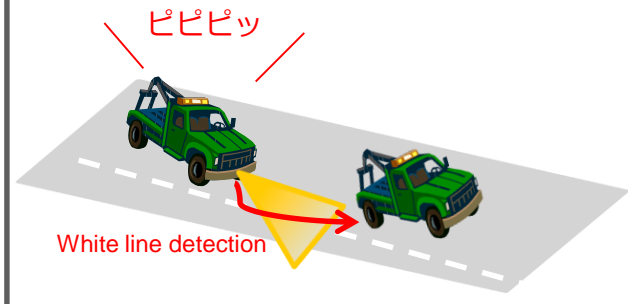
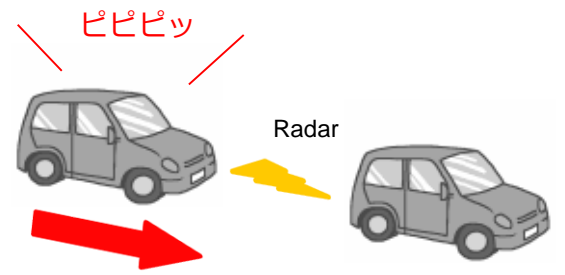

Lane Departure Prevention System

For realizing the safest road transport system in the world

Autonomous + Cooperative

The system realizes advanced driving assistance and automatic driving through a combination of vehicle-to-vehicle communication, high-resolution radar, etc.



Automated Driving Systems

ITS in Japan and their Frequency Allocation

ETC is the Electronic Toll Collection System using **DSRC** in **5.8 GHz** band.

ITS Connect is the Driving Safety Support System using **DSRC** in **760 MHz** band.

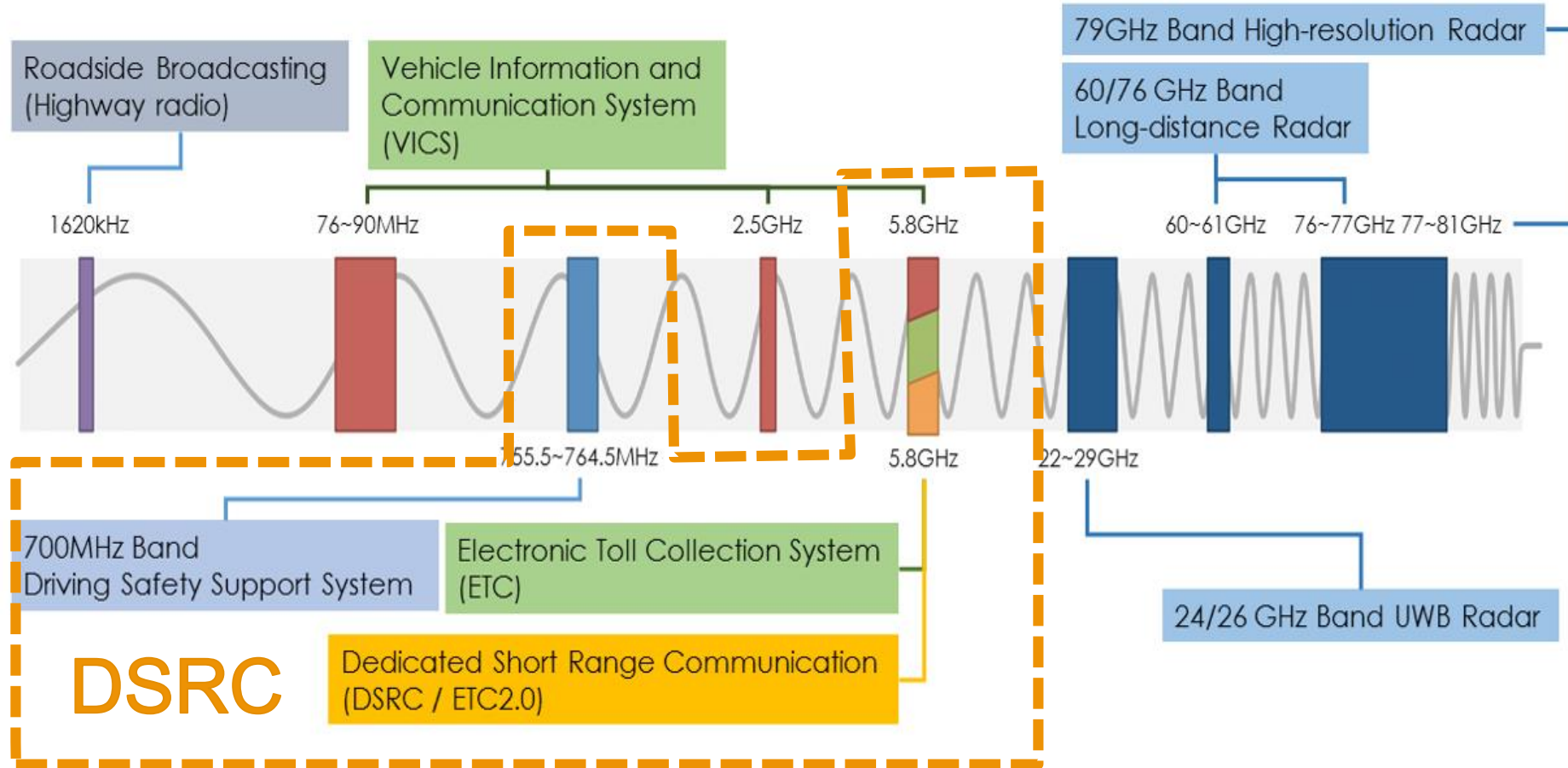

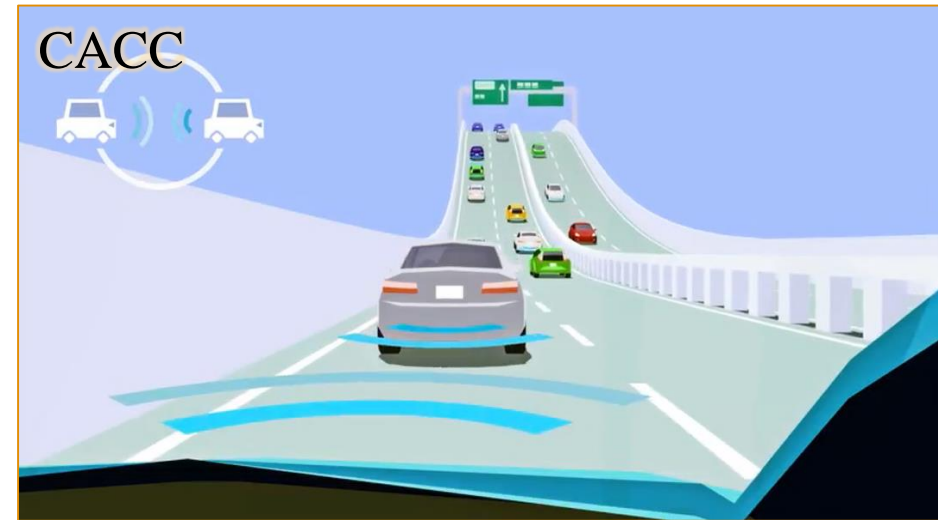

**High speed/
hot-spot communication
(e.g. DSRC, Millimeter-wave)**

**Highly reliable/
direct communication
(e.g. DSRC)**

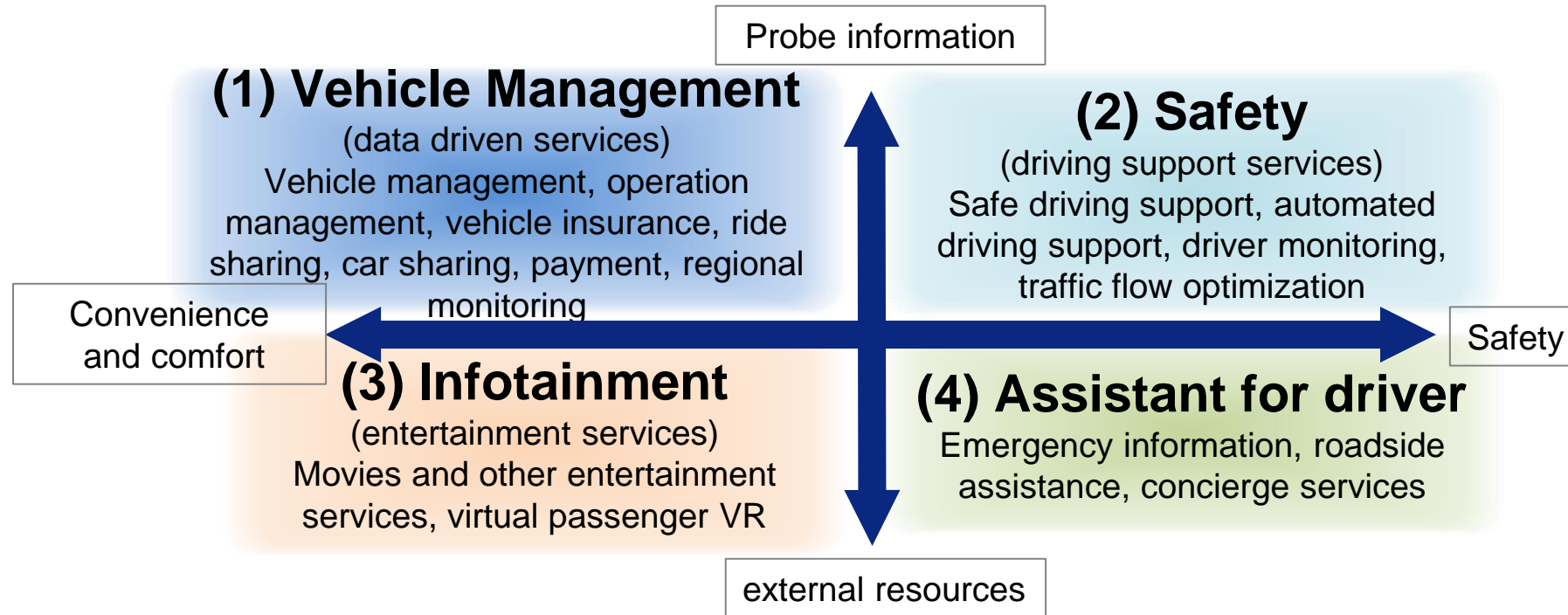

**Wide area communication
(LTE, 5G, etc.)**

Concept image : Connected Car

Setting
The driver has been recognized as Yuji based on key entry and voice/biometric authentication. All the interfaces have been set according to his preferences. His identity number has also been accepted. Driving can now commence

Hello
Good morning. It's your friend Sachiko's birthday today. Would you like to send her a present? Last year you sent roses, and the year before that you sent chocolates. Do you want to see the latest recommendations?

Entertainment
I'm picking up high-quality audio of some new music you might like. There's a list of tunes on the screen. Take a look if you're interested. Let me know if you see something you like. I can sort out the payments and charge them to your account. ... I need your authorization. ... Thank you.

Events
You've invited Sachiko out to dinner tomorrow. I've scanned her online profile, and it looks like she'd prefer Japanese food. Especially fish; she's upvoted a lot of fish recipes recently. I know a good restaurant that's quite popular at the moment. They're currently rated 4.8 out of 5 stars, and the most popular item on the menu is the tuna. ... OK, I'll see if I can reserve you a table. ... Yes, I was able to make a reservation.

Business
Today you're visiting a director called Mr. Suzuki. He was recently promoted to the board of his company. On the way there, we're passing through a town where they sell sweets that have become popular online recently. Perhaps you could pick some on the way? OK, I'll prepare the order for you.

Enhanced Sensor
According to other cars in the area, the left turning up ahead will take us to a stretch of road that's just caved in. I'll take a different route instead. It will only make your journey about 200 meters longer, So don't worry.

Social networking
When you were out driving yesterday, used my built-in camera to take some photos of the cherry blossoms along the river. I think they're really pretty. Do you want to take a look? I can upload them to your profile page if you like.

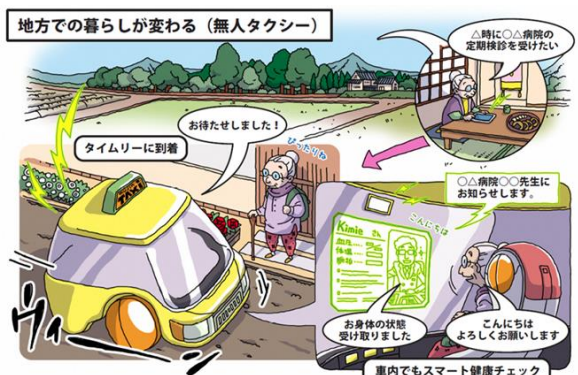

Automatic taxis



Shared vision of the vehicle in front

Valeo(FRA) XtraVue (CEATEC 2018)

Driver Agents providing a comfortable experience

MIC's action

The international frequency status in ITS

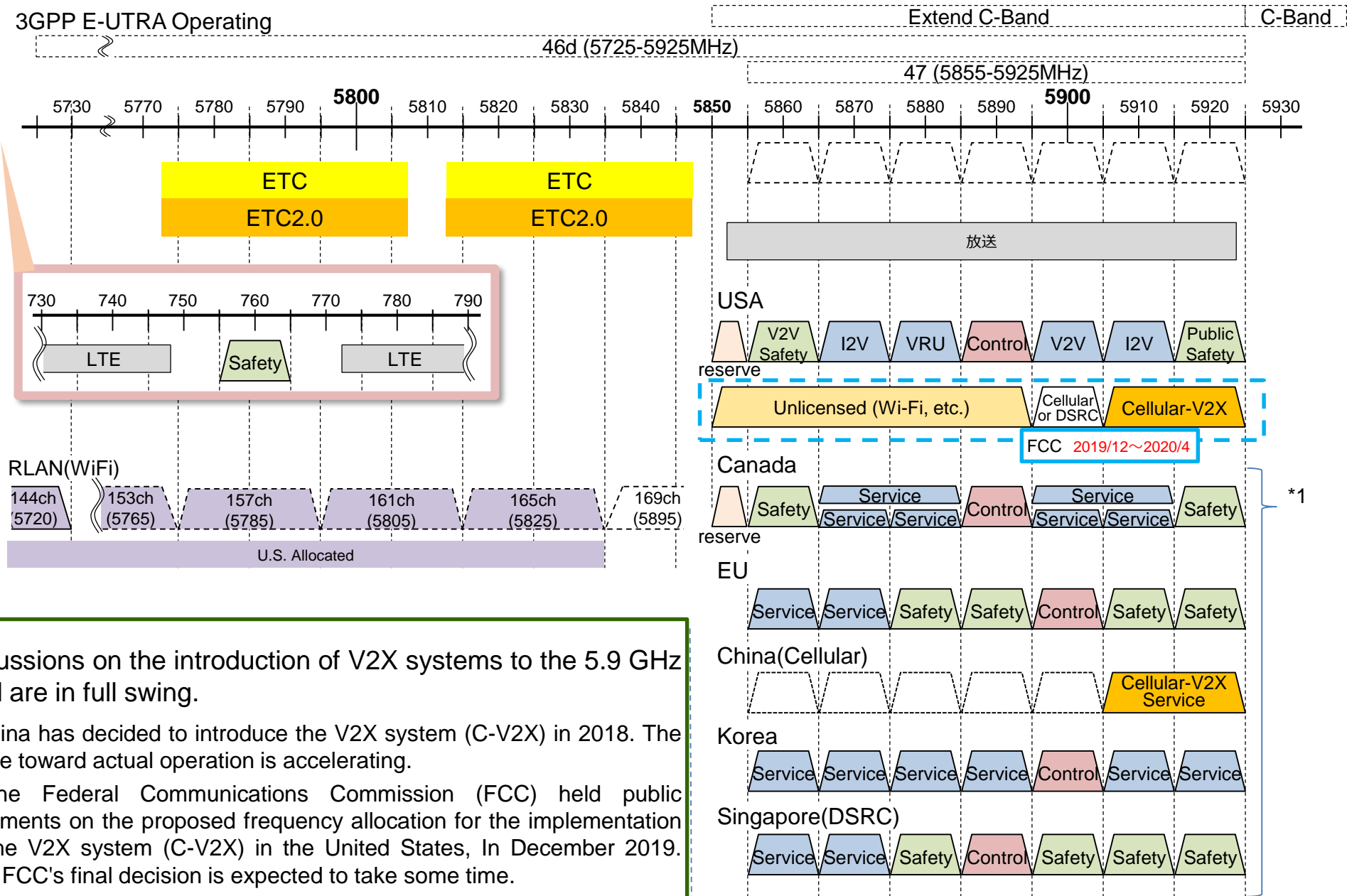

■ Discussions on the introduction of V2X systems to the 5.9 GHz band are in full swing.

- China has decided to introduce the V2X system (C-V2X) in 2018. The move toward actual operation is accelerating.
- The Federal Communications Commission (FCC) held public comments on the proposed frequency allocation for the implementation of the V2X system (C-V2X) in the United States, In December 2019. The FCC's final decision is expected to take some time.

*1) Source of reference : Rep. ITU-R M.2444-0

○Chapter 3 Priority Initiatives III Initiatives for a Self-Driving Society

Based on the progress and importance of automatic driving systems (including safe driving support), a study is being carried out, **which will finish by the end of FY 2021, into the technical conditions for frequency sharing with needed existing wireless systems, for example when introducing V2X communications, and with consideration for existing wireless systems on frequency bands being studied internationally (5.9 GHz band)**, in addition to the existing ITS frequency bands (760 MHz band, etc.).

In addition, based on the results of these studies, **a conclusion will be reached within FY 2022 regarding frequency allocation policy, such as frequency sharing and migration/reorganization when introducing V2X communications in the same frequency band, etc.**

○Chapter 4 Reorganization Policy for Each Frequency Range VII 5.85~23.6GHz Band

⑤ Commercial Broadcasting Radio Stations and Fixed-Satellite Services [5.9GHz Band]

Based on the progress and importance of automatic driving systems (including safe driving support), a study is being carried out, which **will finish by the end of FY 2021, into the technical conditions for frequency sharing with needed existing wireless systems, for example when introducing V2X communications, and with consideration for existing wireless systems on frequency bands being studied internationally (5.9 GHz band)**, in addition to the existing ITS frequency bands (760 MHz band, etc.).

In addition, based on the results of these studies, **in cases where V2X communications are to be introduced on the same frequency band, there is a goal to allocate frequencies to V2X in FY 2023 after the necessary frequency bandwidth has been secured by migrating existing wireless systems, etc.**

Technical study of 5.9 GHz band for V2X communication system (FY2020-2021)

In order to cope with the rapid increase in traffic in the future, we have been conducting technical study for the introduction of the V2X system in the 5.9 GHz band since FY2020.

A technical study is conducted on the possibility of sharing with existing radio systems.

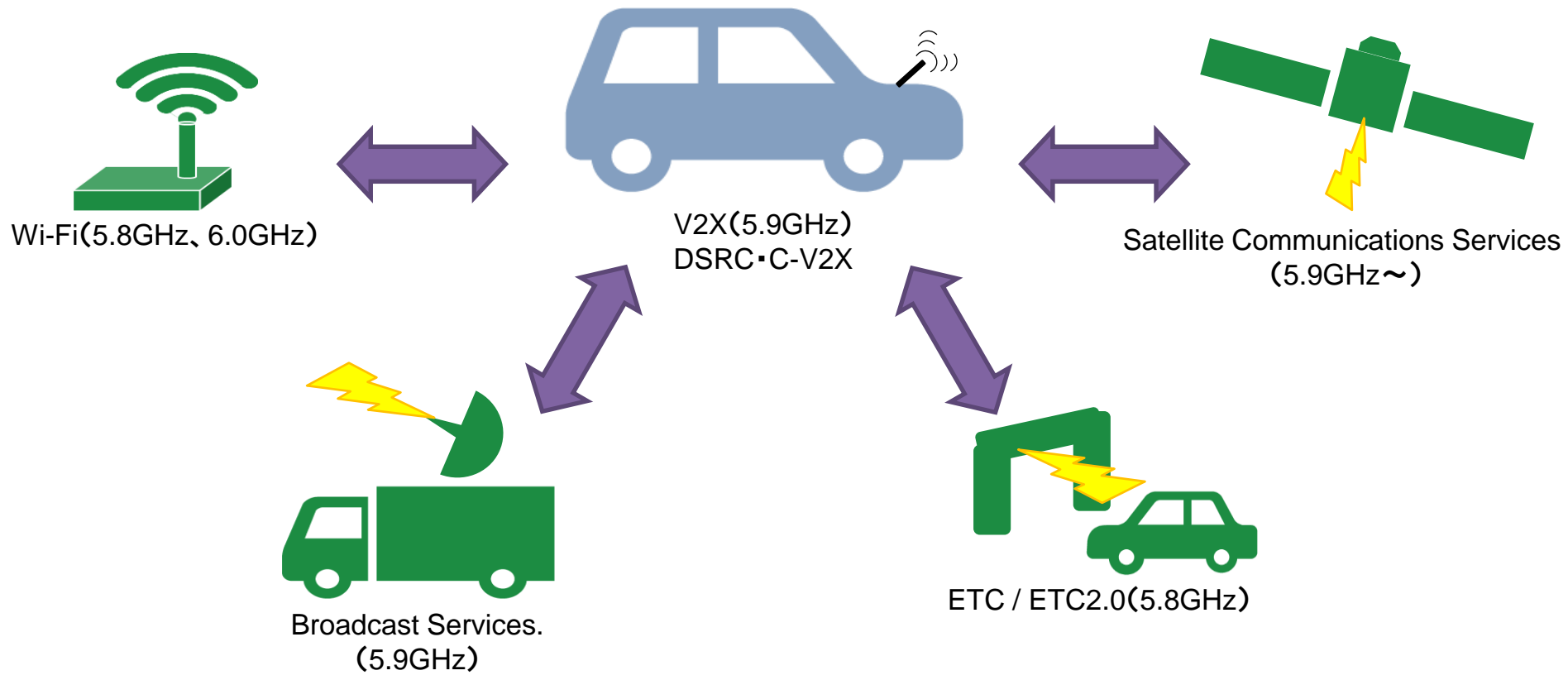

Technical study of communication requirements for automatic driving (SIP:FY2019 - 2021)

- The use cases for V2X communication were studied in FY2019, and 25 use cases have been developed.
- In 25 use cases, we will study the technical requirements for DSRC in the 760 MHz band and V2X communication in the 5.9 GHz band. Then, we will formulate a draft roadmap for the information and communication technologies necessary to realize a highly automated society.(FY2020-)

- We will study the technical requirements for communication for use cases that utilize communication for automated driving.
- Using desktop studies and simulations, we will evaluate whether the existing 760 MHz ITS can be adapted to 25 use cases.
- We will formulate a draft roadmap to determine the timing of wireless communication technology based on the time of implementation of automated driving cars and other factors.

Example of Use Case

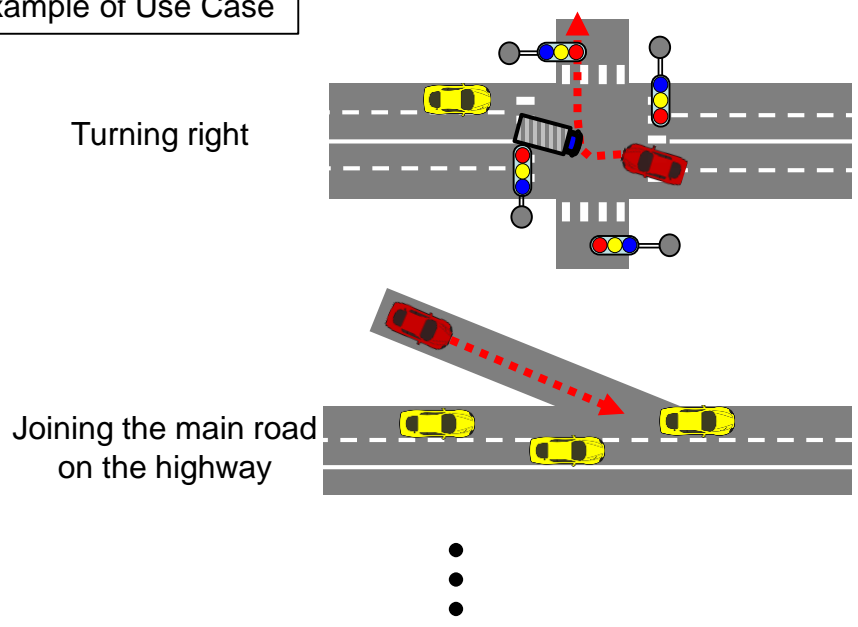

Example of a roadmap

		20XX	20XX		
		展開期	成熟期		
合流支援					
技術要件	車車/路車	路車	路車		
	情報項目/情報量	合流地点到達予測時刻 本線平均車速	合流地点到達予測時刻 本線現在車速		
通信要件	遅延	XXms	XXms		
	データ量	XXbps	XXbps		
	遅延	X回/100ms	X回/100ms		
	パケット到達率	XX%	XX%		
	到達距離	XXm	XXm		
通信方式	狭域通信	ARIBT75			
		ARIBT109			
	広域通信	LTE			
		5G			
周波数		XXX	XXX		
帯域		YY	YY		

In addition to the technical study of 5.9 GHz band for V2X communication system, we will technically evaluate the possibility of introducing V2X communication to the 5.9 GHz band.

Small-scale NW and Mid-scale NW information processing (SIP:FY2019-2020)

- Develop and organize dynamic traffic information.
- Optimize the information process with multi-scaled network through the combination of V2I/V2P/V2N technology and roadside sensing technologies.

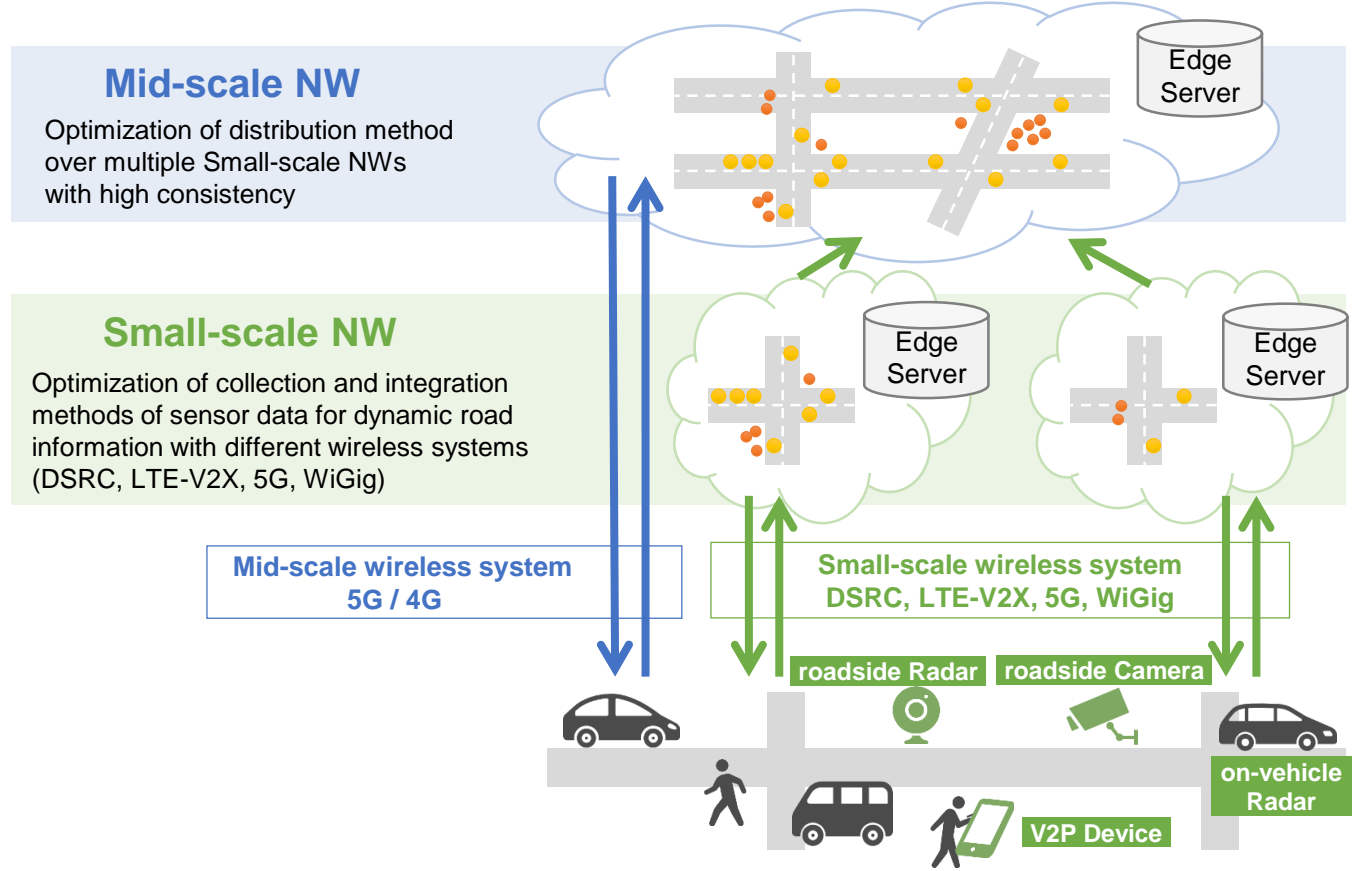

Optimization of processing methods for dynamic road information by introducing multi-scale network architecture (Mid-/Small-scale NW); Collection, Integration and Distribution.

Truck platooning by New Radio (NR) V2V (FY2017-2019)

- We conducted a demonstration of truck platooning to control the inter-vehicle distance automatically on the expressway (Shin-Tomei) for examination of coordinated adaptive cruise control. Trucks exchanged images and information by **direct Ultra-Low Latency NR-V2X (V2V) Communication**.

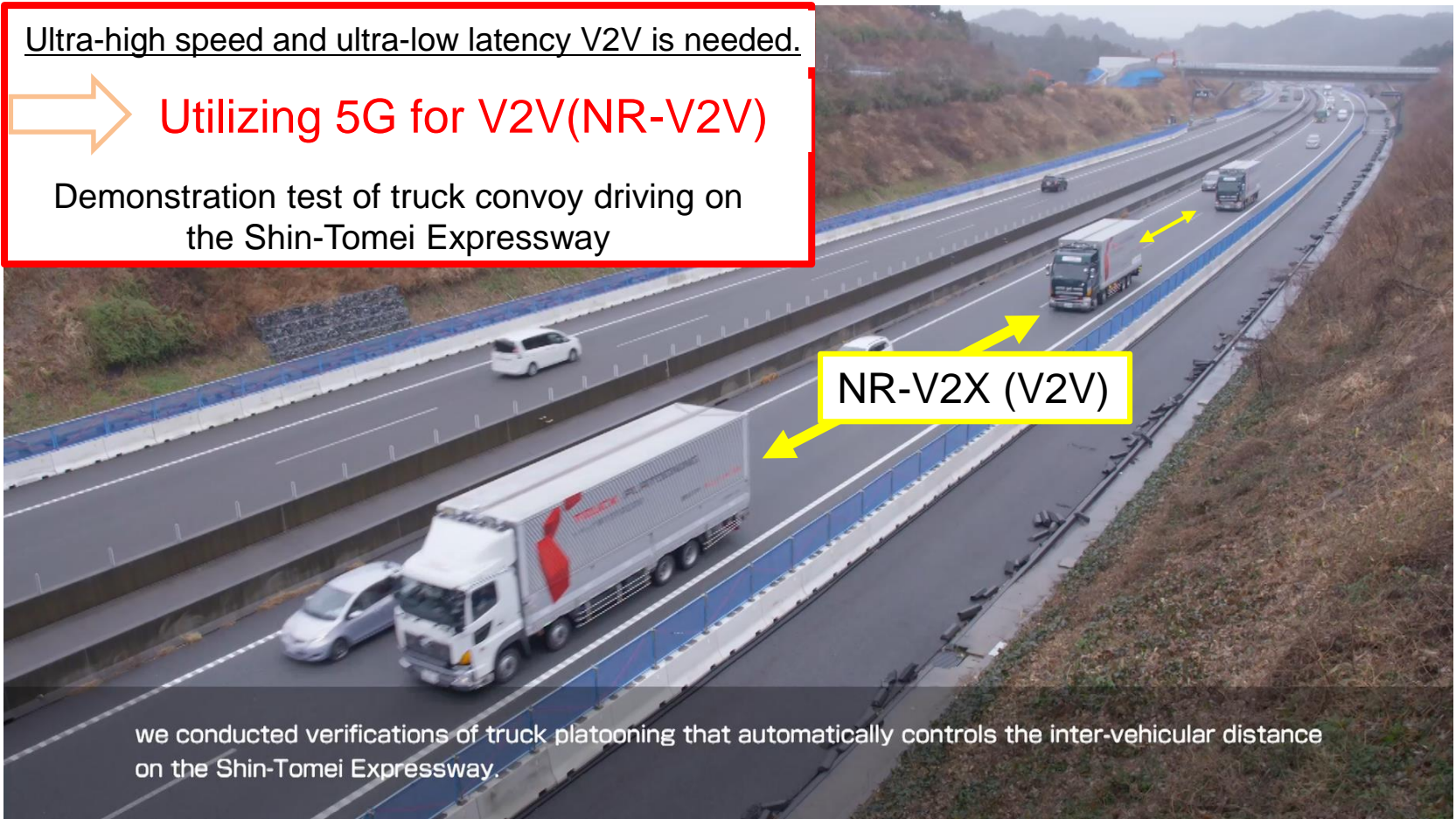

Remote control of construction machine by 5G

- ✓ In the affected areas, it is hoped that roads and other structures damaged by landslides will be restored as soon as possible.
 - ✓ It takes time to recover in these places. In addition, there is a problem of ensuring the safety of the workers engaged in the restoration work.
- ⇒ **Remote control of construction equipment is required.**

Required

- High-definition images for recognize the surroundings.
- Low latency control to ensure safety

➔ **Ultra-high speed and ultra-low latency communication**

➔ **Remote control by 5G**

Remote control of heavy construction equipment was conducted in Ibaraki City, Osaka Prefecture. (February 2019)

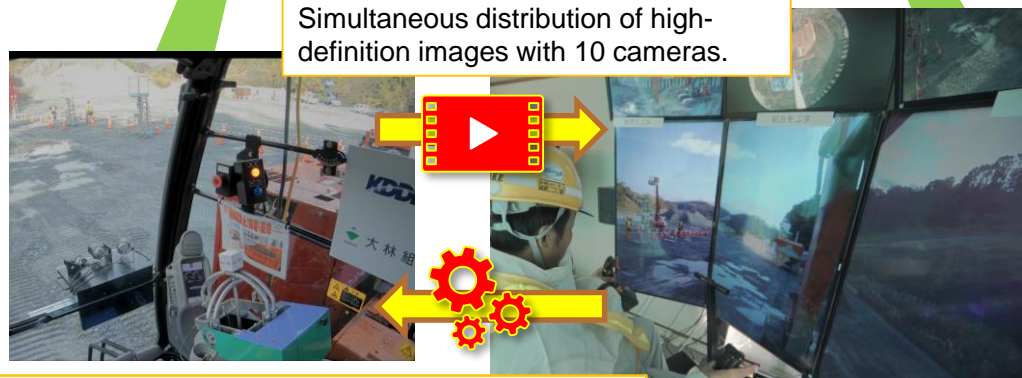
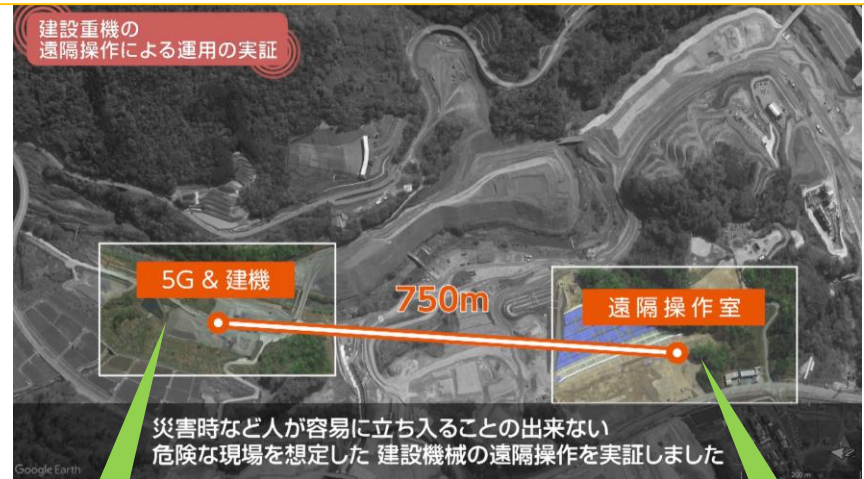

Simultaneous distribution of high-definition images with 10 cameras.

Remote control while viewing images transmitted by 5G from cameras installed in construction machine

We are verifying of Japan's V2X system in India, the Philippines, and Taiwan.
Based on the results, we will also promote the introduction of these systems at the site.

Demonstration in India

【Location】 Ahmedabad, Gujarat, India 【Date and time】 2020/1/17

【Background】 Traffic congestion on the roads to the hospital is causing delays in the Emergency Vehicle.

【Content】 Information on approaching emergency vehicles will be displayed on an electronic bulletin board to encourage nearby vehicles to change lanes.

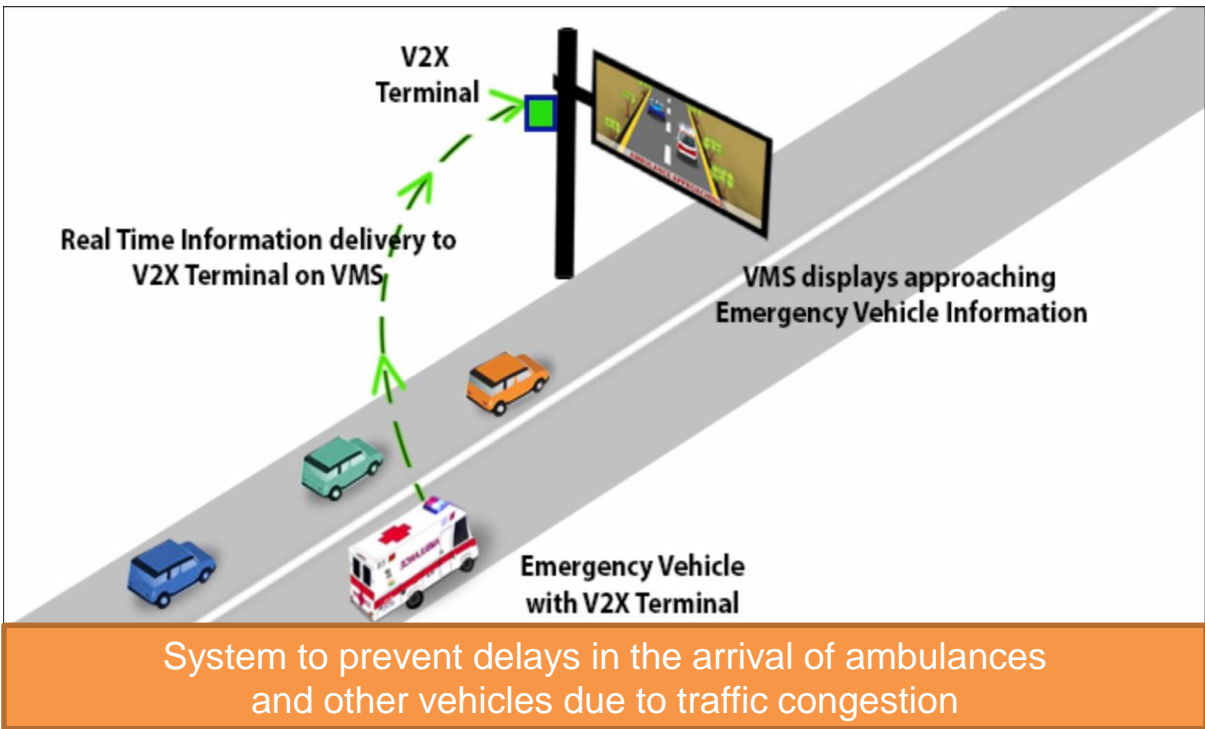

Demonstration in Ahmedabad



Inspection of the demonstration by the commissioner of Ahmedabad

Thankyou for listening.

